



# RECESSED DOOR TO RECEIVE DRYWALL

## Model RDWPD

### WITH FACTORY INSTALLED DRYWALL



**KARP ASSOCIATES, INC.**  
 260 Spagnoli Road Melville, NY 11747  
 (631) 768-8300 - Phone  
 (631) 768-8350 - Fax

DATE

#### SPECIFICATIONS

##### GENERAL SCOPE:

Access doors shall be Karp Type RDWPD as manufactured by Karp Associates, Inc., Melville, N.Y. Sizes shall be as indicated on the drawings.

##### CONSTRUCTION:

1. Frame shall be 14 gage steel and doors shall be 16 gage steel.
2. Door shall be recessed 1/2" with factory install 1/2" drywall.
3. Trim shall be galvanized steel dry wall bead.
4. Hinge shall be concealed pivoting rod type.
5. Locks shall be flush and screwdriver operated with cam and studs, or shall be key operated cylinder lock with automatic dust shutter.
6. Finish shall be prime coat of rust inhibitive electrostatic powder, baked white enamel.

##### STANDARD SIZES

DOOR SIZE H X W (IN.)	WALL/CEILING OPENING (IN.)	NUMBER OF LATCHES	SHIP WT. (LBS.)
12 x 12	12 1/8 x 12 1/8	1	8
18 x 18	18 1/8 x 18 1/8	2	15
24 x 12	24 1/8 x 12 1/8	2	14.5
24 x 24	24 1/8 x 24 1/8	4	24.5
36 x 24	36 1/8 x 24 1/8	5	36.5

#### PROJECT DATA

Project Name:
Architect:
Contractor:
Agent/Customer Name:
Tagging Instructions:
Special Instructions:

#### PROJECT SCHEDULE

Qty.	H	W	No. of Latches	Finish	Remarks

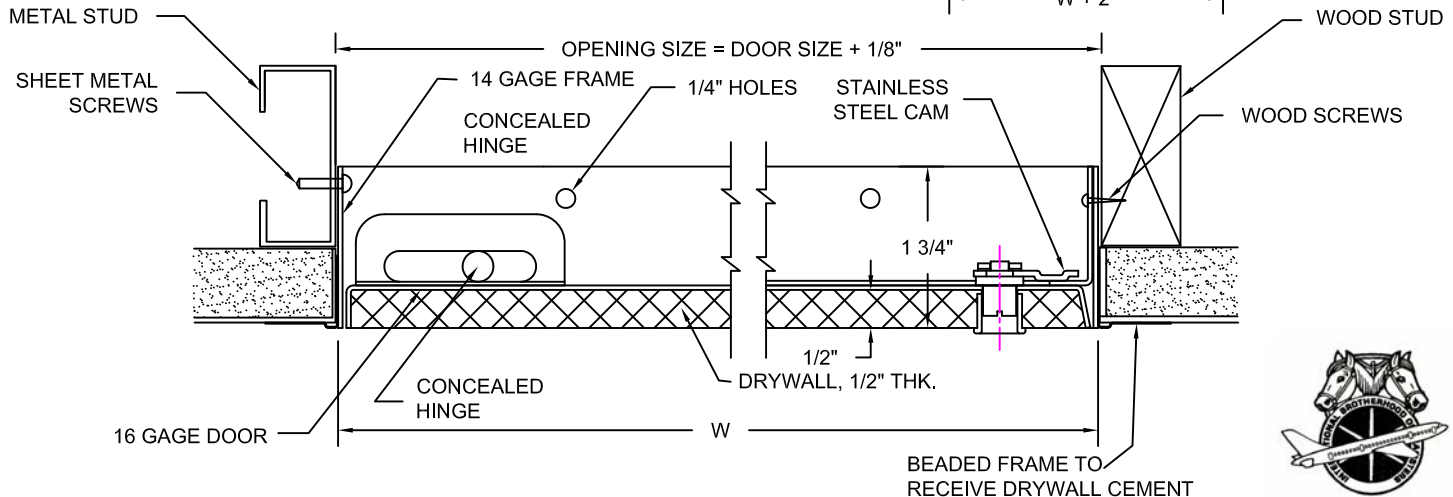
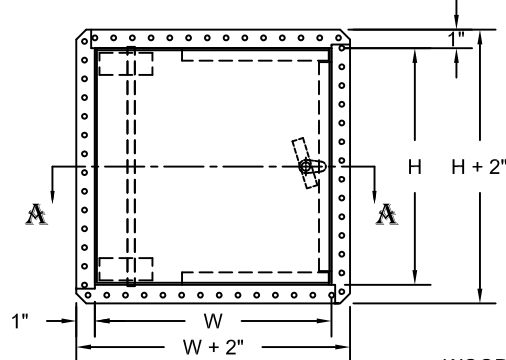

**SECTION A-A**



**Made with Union Labor**