

CONTENTS	2-door	4-door
1. TRACK (9601)	1	1
2. CARRIER (9572)	1	2
3. QUICK RELEASE PLATE (9610)	1	2
4. PIVOT SET (9618)	1	2
5. BI-FOLD ALIGNER (9559)	-	2
6. BUMPER STOP (9815)	1	2
7. PULL (9558)	1	2
8. BI-FOLD HINGE (9220)	3	6
9. #8 X 3/4" PPHS	-	4
10. #8 X 1" PPHS	16	36
11. #8 X 1-3/4" PPHS	1	2
12. #10 X 3/4" FHS	3	6
13. #8 X 7/8" FHS	12	24

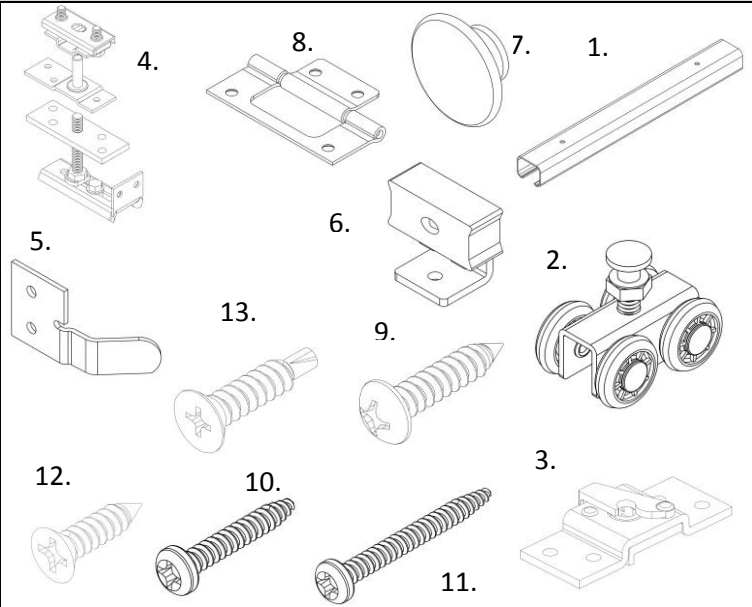

# 1 PREPARE OPENING

OPENING HEIGHT MAX = DOOR HEIGHT + 3-1/2"  
OPENING HEIGHT MIN = DOOR HEIGHT + 2-1/4"

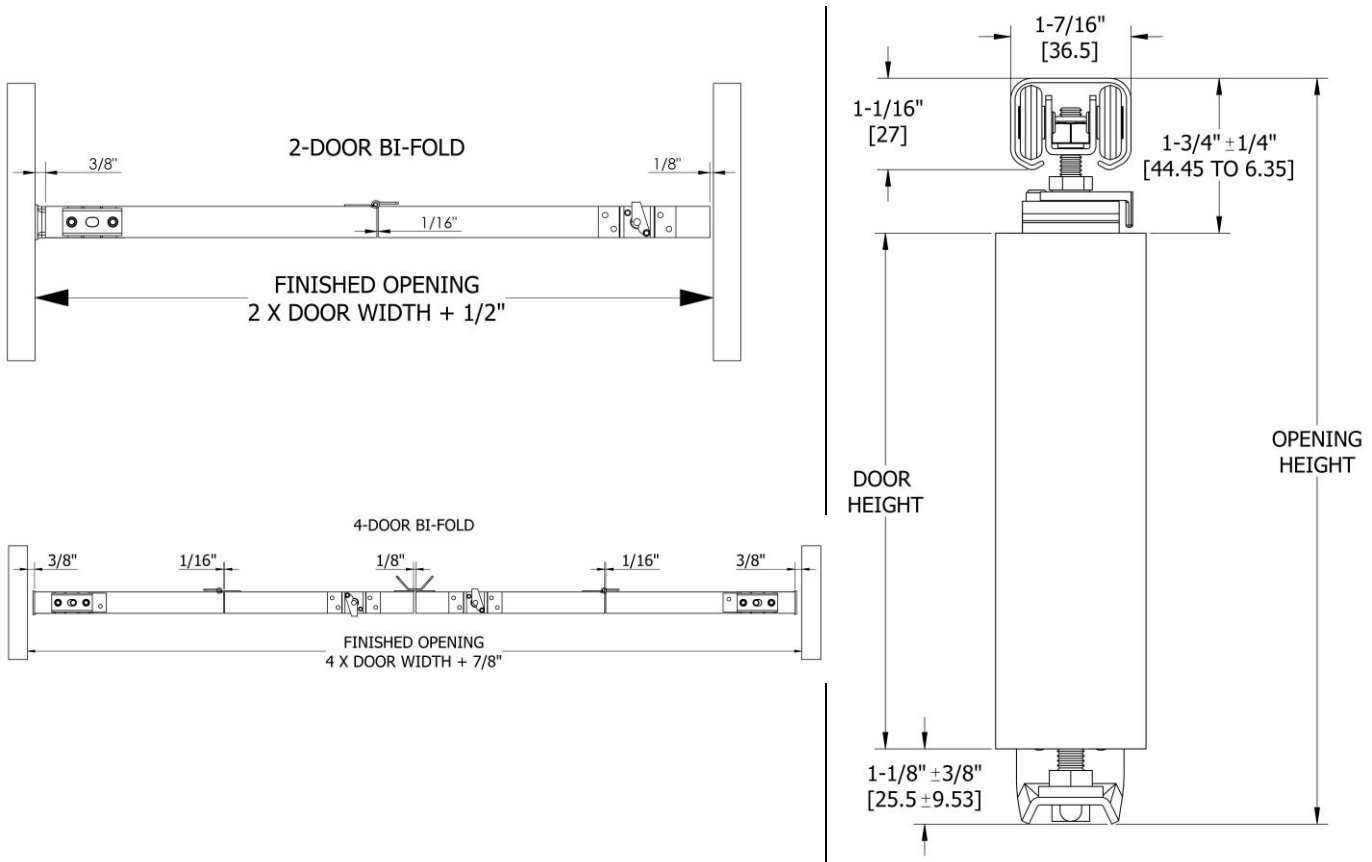

## 2 INSTALL TRACK AND HARDWARE

- Line up track flush against jamb on guide door side for 2-door, center track in opening for 4-door (Track length should be 1/8" less than opening width)
- Place Top pivot bracket and hangers loose in track **before** securing track with (#8x1") screws
- Position top pivot bracket center 2-1/8" from jamb and hand tighten,
- Secure bottom bracket in jamb corner with (#8x3/4") screws.
- Center quick release and pivot plates on door thickness
- Mount top and bottom pivot plates 1-3/4" from center to pivot door edge. (Fig 1)
- Mount quick release plate 1-1/4" from center to guide door edge (fig 2)
- Secure plates onto door with (#8x1-1/2") screws
- Drill 3/16" guide hole in center of guide door and secure pull with (#8X1-3/4") screw (Fig 2)
- To install hinges place doors side by side as if folded. Secure with (#8x7/8") screws. (Fig 2)

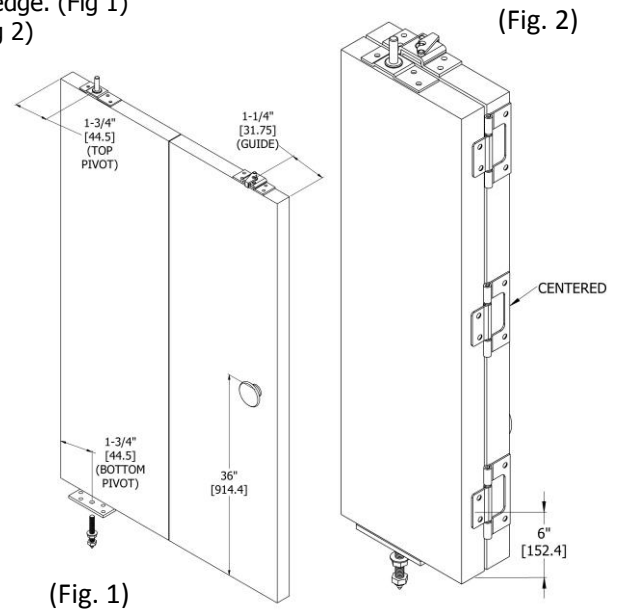
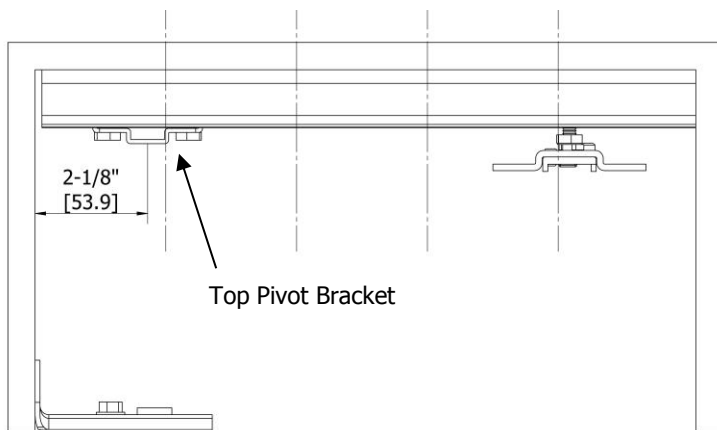

## 3 HANG DOORS

- Fold doors together and engage top pivot into top pivot bracket
- Set bottom pivot assembly into serrations in jamb bracket
- Slide carrier bolt into quick release mount plate and close latch.

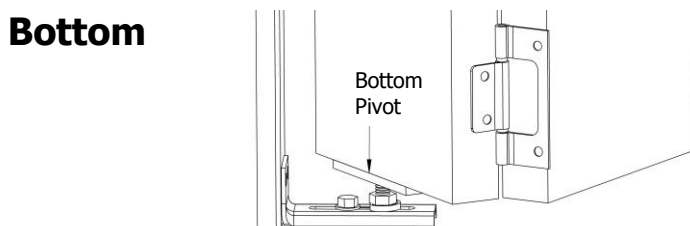
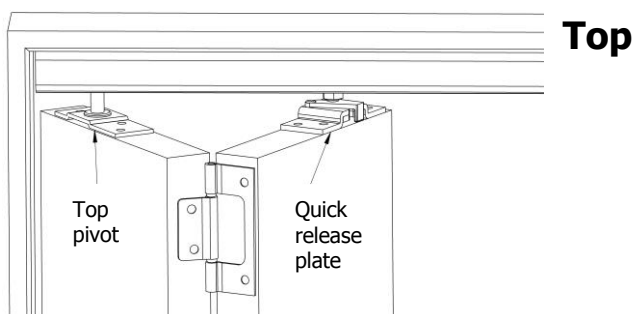

## 4 ADJUST AND FINISH

- Adjust carriers and pivots so door is square with frame
- Slide jam bracket carrier in or out to adjust tilt.
- Install aligners in back, about 12" from bottom with (#8x3/4") screws. (4 door install only)
- Install stops between top guide and side jamb furthest from pivot for 2 door and in the middle between the two pairs of doors for 4 doors.

