

4500 RIM DEVICE WITH 4900 MULLION DOOR PREP TEMPLATE

APPLICATION FOR METAL AND WOOD DOORS (FOR PANIC AND FIRE RATED DEVICES)

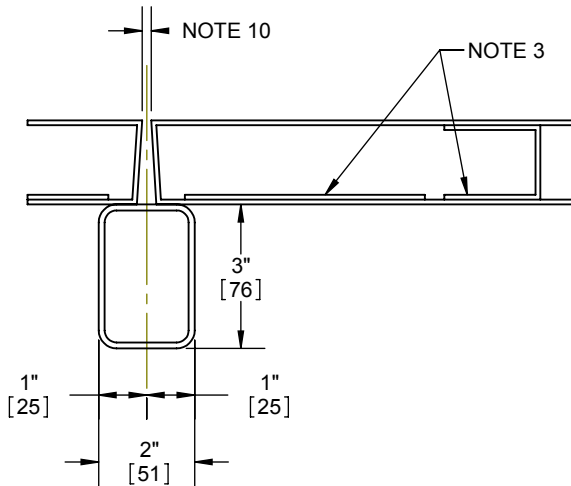

NOTES:

1. Preparation is typical for both doors.
2. Minimum Stile width:
 - 5 3/4" for double doors with 2" mullion.
3. Provide door stiffeners as needed to prevent door collapse due to installation with power tools, door use, or abuse.
4. Device mount (end cap bracket) to hinge stile (not shown) requires hole location and preparation during device installation.
5. For outside trim preparation see appropriate trim template.
6. Recommended height may be determined by design spec's.
7. A $\phi 1/2$ " hole is required if using the electric trim (45ET).
8. Device mounting holes (4 places)
 - Metal door: 1/4"-20 Tap (std.).
 - Wood door (solid core): Pre-drill $\phi 1/8$ " holes.
 - SNB: $\phi 5/16$ " inside door face, $\phi 3/8$ " outside door face.
 - Trim: $\phi 5/16$ " inside door face, $\phi 1/2$ " outside door face.
 - Check building and fire codes to see if your application requires the use of SNB (sleeve nuts and bolts).
9. Trim Tailpiece hole:
 - For BE and CE trim: $\phi 5/8$ " (thru hole)
 - Dummy trim: not required
 - Night Latch trim: See template T-ED00344 for details.
10. Per ANSI/SDI A250.8, pairs of doors $3/16" \pm 1/16"$, and fire rated pair $1/8" \pm 1/16"$. Consult design spec's before preparing doors.
11. Strike to be field mounted using exit device installation instructions.
12. Fire rated devices require 4912 Fire Rated Strike and Hook.

