

ITEM NO.	FILE NAME	DESCRIPTION	QTY.
1	S-LS00007	3940 DEADBOLT LATCH (2-3/4" BACKSET)	1
2	S-LS00728	CYLINDER ROSE	1
3	S-LS00726	CYLINDER ROSE LINER	1
4	S-LS00718	EXTERIOR THUMBTURN CYLINDER HOUSING - IC	1
4.6	S-LS00363	IC CORE TAILPIECE (2-639-7095)	1
5	S-LS00717	INSIDE THUMBTURN ASSEMBLY	1
6	S-LS00723	DEADBOLT STRIKE	1
7	S-LS00724	DEADBOLT WOOD REINFORCER	1
8	S-LS00725	DEADBOLT DUST BOX	1
9	S-LS00379	IC CORE CYLINDER FIRE SHIELD	1
10	S-LS00883	CUSTOM #12-24 X 2-5/8" FPHMS	2
11	S-LS00550	INTERCHANGEABLE CORE	1
12	S-LS00885	CUSTOM #10 X 3" FPHWS	2
13	S-LS00882	#8 X 1-1/4" FPH COMBO SCREW	2
14	S-LS00882	#8 X 3/4" FPH COMBO SCREW	2
15	pan cross head_ai	#8-32 X 1/4" PHMS	2

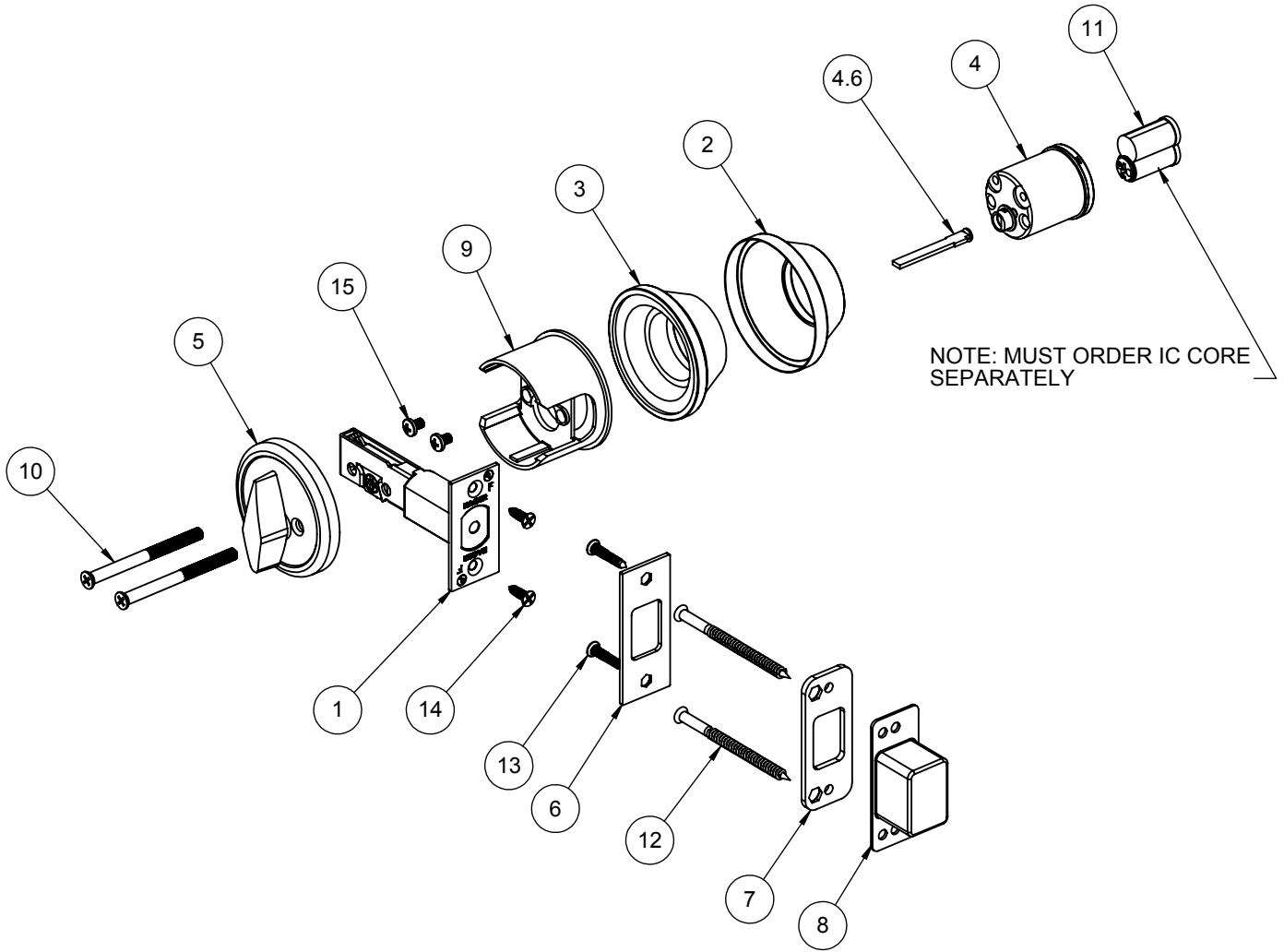

PROPRIETARY & CONFIDENTIAL
 THE INFORMATION CONTAINED IN THIS DRAWING IS THE SOLE PROPERTY OF HAGER COMPANIES. ANY REPRODUCTION IN PART OR AS A WHOLE WITHOUT THE WRITTEN PERMISSION OF HAGER COMPANIES IS PROHIBITED.

HAGER RESERVES THE RIGHT TO MAKE DESIGN CHANGES WITHOUT NOTICE. CALL HAGER ENGINEERING AT 1-800-325-9995 FOR THE LATEST REVISION DATE OF TEMPLATE.

MATERIAL	Material <not specified>
FINISH	-
DO NOT SCALE DRAWING	

DRAWN	MRJ	9/9/2009
ENG. APPR.	-	-
Q.A.		
TOLERANCES: FRACTIONAL: ±0.015" ANGULAR: MACH: ±1° BEND: ±1° TWO PLACE DECIMAL: ±0.01" THREE PLACE DECIMAL: ±0.004"		

3215		REV.	
GRADE 2 - CYLINDER X THUMBTURN IC DEADBOLT		-	
SIZE	DWG. NO.	REV.	
A	S-LS00828	-	
SCALE: 1:4	WEIGHT: 1.89	SHEET 1 OF 1	