

ITEM NO.	FILE NAME	DESCRIPTION	QTY.
1	S-LS00718	EXTERIOR DOUBLE CYLINDER HOUSING	1
2	S-LS00718	INTERIOR DOUBLE CYLINDER HOUSING	1
3	S-LS00617	6-PIN DRILLED CYLINDER	1
3.3	S-LS00218	INTERIOR TAILPIECE (2-639-7006)	1
4	S-LS00617	6-PIN DRILLED CYLINDER	1
4.2	S-LS00217	EXTERIOR TAILPIECE (2-639-7005)	1
5	S-LS00884	CUSTOM #12-24 x 3-1/4"OPHMS	2
6	S-LS00885	CUSTOM #10 X 3" FPHWS	2
7	S-LS00882	#8 X 1-1/4" FPH COMBO SCREW	2
8	S-LS00882	#8 X 3/4" FPH COMBO SCREW	2
9	S-LS00367	ROSE	2
10	Flat Washer Narrow_AM	3.5MM NARROW FLAT WASHER	1
11	Pan Cross Head_AI	#8-32 X 1/4" PHMS	3
12	S-LS00007	3940 DEADBOLT LATCH (2-3/4" BACKSET)	1
13	S-LS00723	DEADBOLT STRIKE	1
14	S-LS00725	DEADBOLT DUST BOX	1
15	S-LS00724	DEADBOLT WOOD REINFORCER	1
16	S-LS00379	STANDARD CYLINDER FIRE SHIELD	1

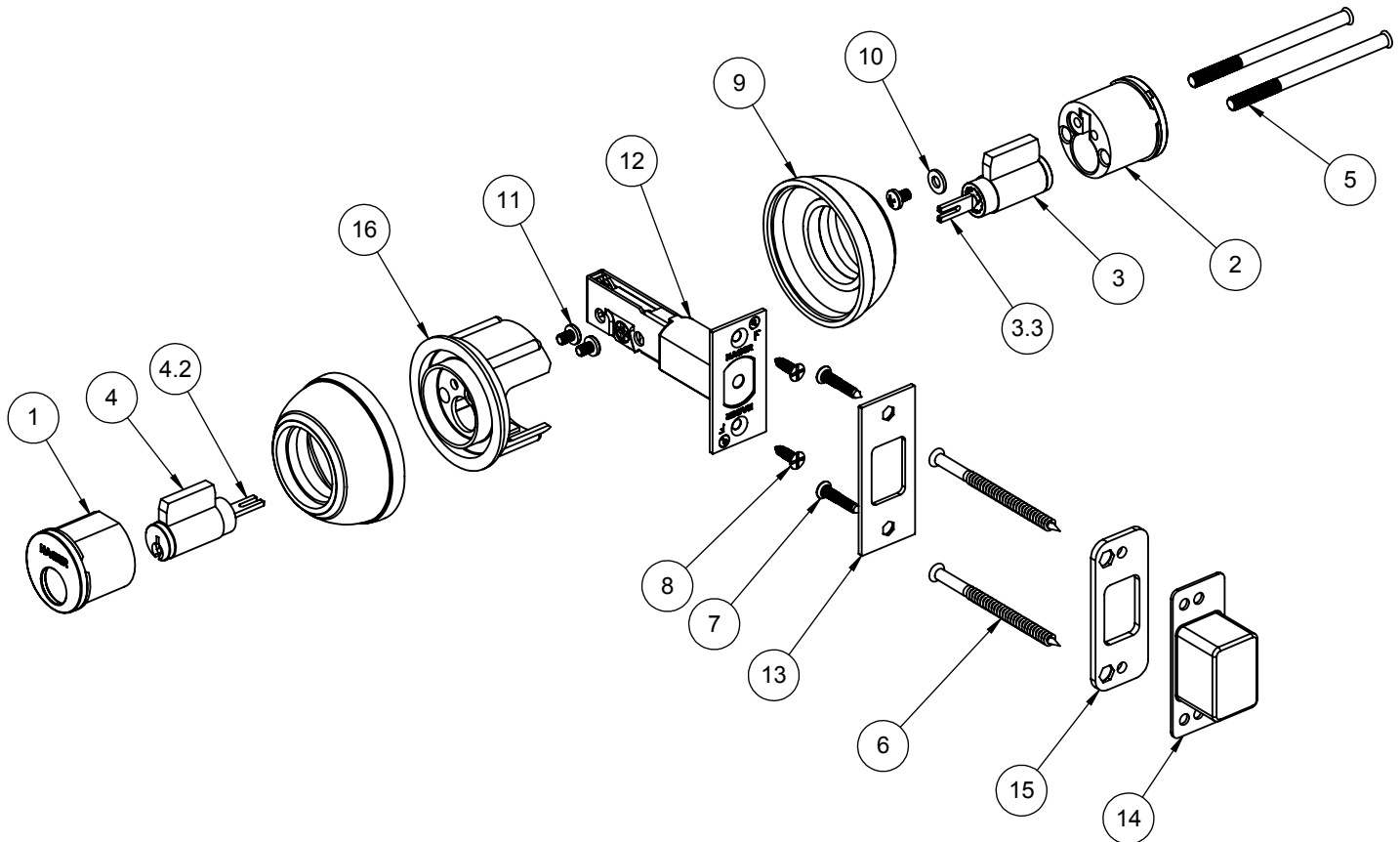

NOTE: (2) KEYS PROVIDED



PROPRIETARY & CONFIDENTIAL
 THE INFORMATION CONTAINED
 IN THIS DRAWING IS THE SOLE
 PROPERTY OF HAGER
 COMPANIES. ANY REPRODUCTION
 IN PART OR AS A WHOLE WITHOUT
 THE WRITTEN PERMISSION OF
 HAGER COMPANIES IS PROHIBITED.

HAGER RESERVES
 THE RIGHT TO
 MAKE DESIGN
 CHANGES
 WITHOUT NOTICE.
 CALL HAGER
 ENGINEERING AT
 1-800-325-9995
 FOR THE LATEST
 REVISION DATE
 OF TEMPLATE.

MATERIAL	Material <not specified>
FINISH	-
DO NOT SCALE DRAWING	

DRAWN	MRJ	1/9/2010
ENG. APPR.	-	-
TOLERANCES:		
FRACTIONAL: ±0.015"		
ANGULAR: MACH: ± 1° BEND: ±1°		
TWO PLACE DECIMAL: ±0.01"		
THREE PLACE DECIMAL: ±0.004"		

3114		
GRADE 1 - DOUBLE CYLINDER DEADBOLT		
SIZE	DWG. NO.	REV.
A	S-LS00880	02
SCALE: 1:4	WEIGHT: 1.70	SHEET 1 OF 1