

Key-Locking Non-Locking

| REVISIONS | | DATE | APPROVED |
|-----------|------|-------------|----------|
| ZONE | REV. | DESCRIPTION | |
| | | | |
| | | | |

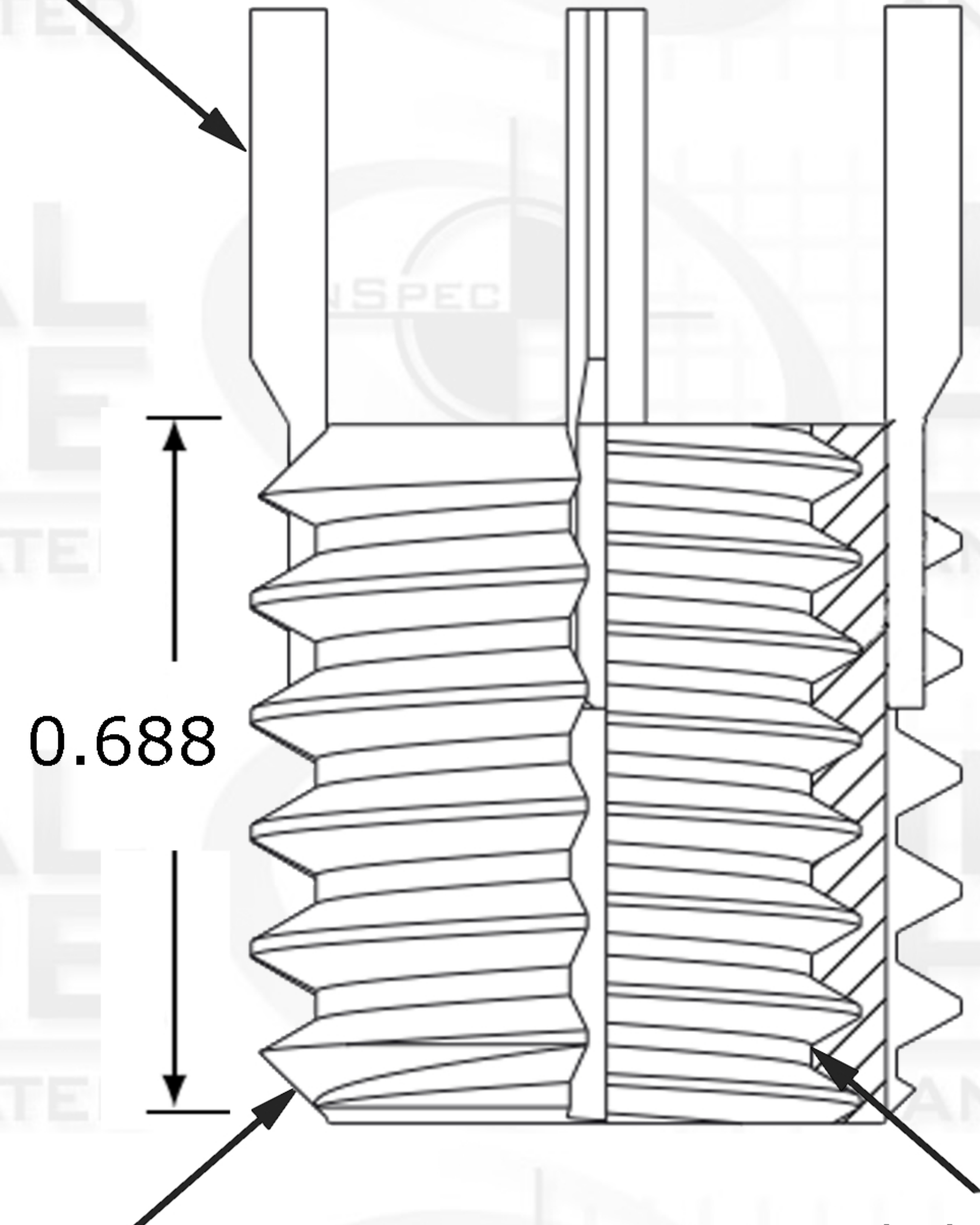

Key



0.688

External Thread Pitch
11/16-11

Internal Thread Pitch
1/2-20

Suggested Drill Bit Size

0.6407 (41/64)



PROPRIETARY AND CONFIDENTIAL

THIS DRAWING AND IT'S CONTENT IS THE SOLE PROPERTY OF INDUSTRIAL HARDWARE & SPECIALTIES,INC.. ANY REPRODUCTION IN PART OR AS A WHOLE WITHOUT THE WRITTEN PERMISSION OF INDUSTRIAL HARDWARE & SPECIALTIES,INC. IS STRICTLY PROHIBITED.

| Internal | NAME | DATE |
|---------------------------|----------------------|------|
| TH. STANDARD: ANSI/ASME | DRAWN | |
| ACRONYM: UNF | CHECKED | |
| ROTATION: Right-Hand | ENG APPR. | |
| External | MFG APPR. | |
| TH. STANDARD: ANSI/ASME | Q.A. | |
| ACRONYM: 11NS | | |
| ROTATION: Right-Hand | | |
| MATERIAL FINISH | | |
| Stainless Steel Type A286 | | |
| PART NUMBER | | |
| 35L8C-7T1J-50-05 | | |
| COMMENTS: | | |
| NEXT ASSY | USED ON | |
| APPLICATION | DO NOT SCALE DRAWING | |



17-B KENTUCKY AVENUE
PATERSON, NEW JERSEY 07503
TEL: 973-684-4010 FAX: 973-684-3095
email: TechSupport@industrialhardware.com
www.industrialhardware.com

| | | |
|-----------|----------|--------------|
| SIZE | DWG. NO. | REV. |
| A | | |
| SCALE:1:8 | WEIGHT: | SHEET 1 OF 1 |