

Key-Locking Internal Locking

REVISIONS		DATE	APPROVED
ZONE	REV.	DESCRIPTION	

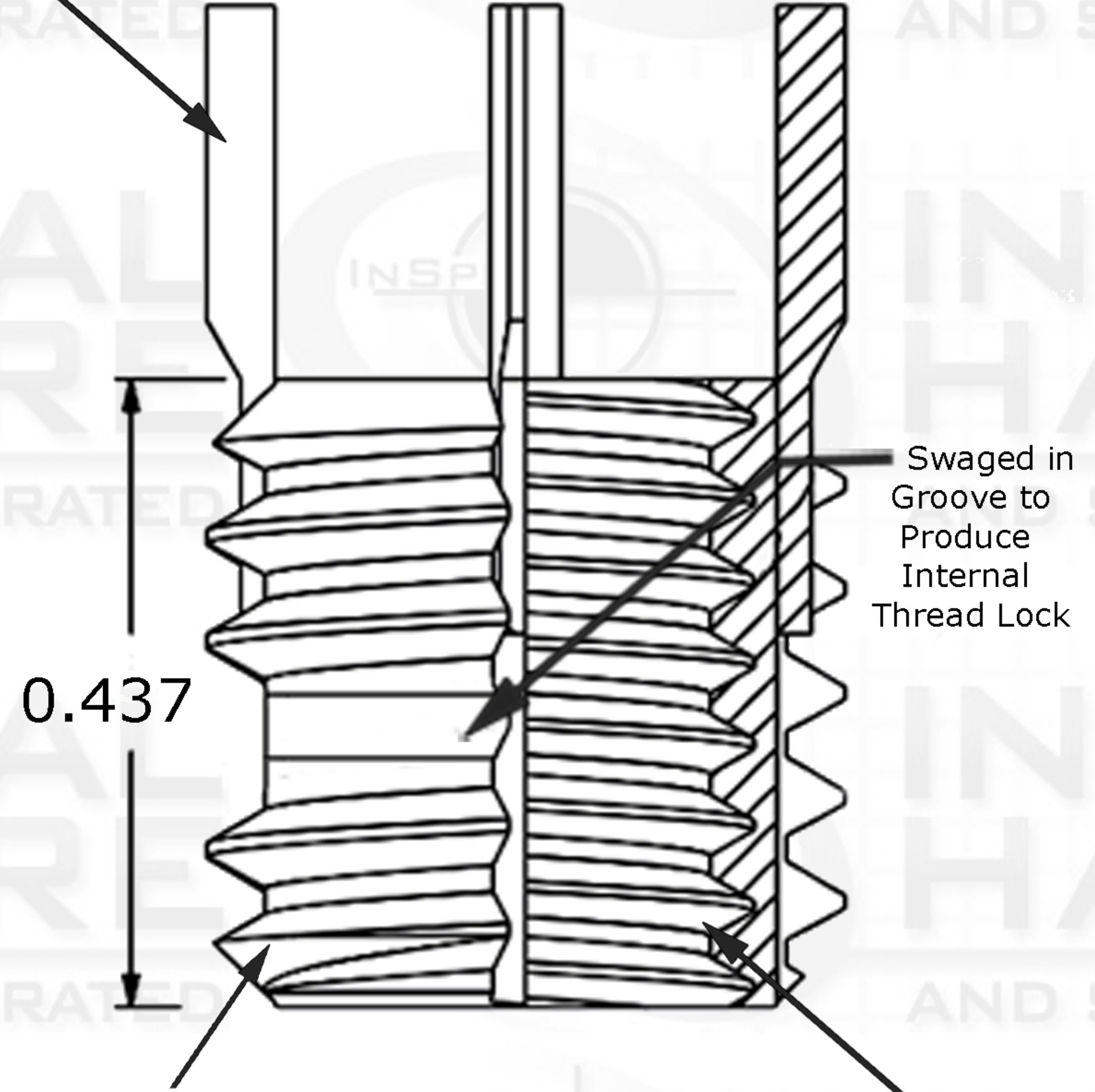

Key



0.437

External Thread Pitch
7/16-14

Internal Thread Pitch
5/16-18

Suggested Drill Bit Size



0.3970 (Letter X)

PROPRIETARY AND CONFIDENTIAL

THIS DRAWING AND IT'S CONTENT IS THE SOLE PROPERTY OF INDUSTRIAL HARDWARE & SPECIALTIES,INC.. ANY REPRODUCTION IN PART OR AS A WHOLE WITHOUT THE WRITTEN PERMISSION OF INDUSTRIAL HARDWARE & SPECIALTIES,INC. IS STRICTLY PROHIBITED.

		Internal		NAME	DATE
		TH. STANDARD : ANSI/ASME	DRAWN		
		ACRONYM: UNC	CHECKED		
		ROTATION: Right-Hand	ENG APPR.		
		External	MFG APPR.		
		TH. STANDARD : ANSI/ASME	Q.A.		
		ACRONYM: UNC			
		ROTATION: Right-Hand			
		MATERIAL FINISH			
		Stainless Steel Type A286	COMMENTS:		
NEXT ASSY	USED ON	PART NUMBER			
		35L8C-7QJ0-31-0A			
APPLICATION		DO NOT SCALE DRAWING			



**17-B KENTUCKY AVENUE
PATERSON, NEW JERSEY 07503
TEL: 973-684-4010 FAX: 973-684-3095
email: TechSupport@industrialhardware.com
www.industrialhardware.com**

SIZE	DWG. NO.	REV.
A		
SCALE:1:8	WEIGHT:	SHEET 1 OF 1