

# Key-Locking Non-Locking

REVISIONS		DATE	APPROVED
ZONE	REV.	DESCRIPTION	

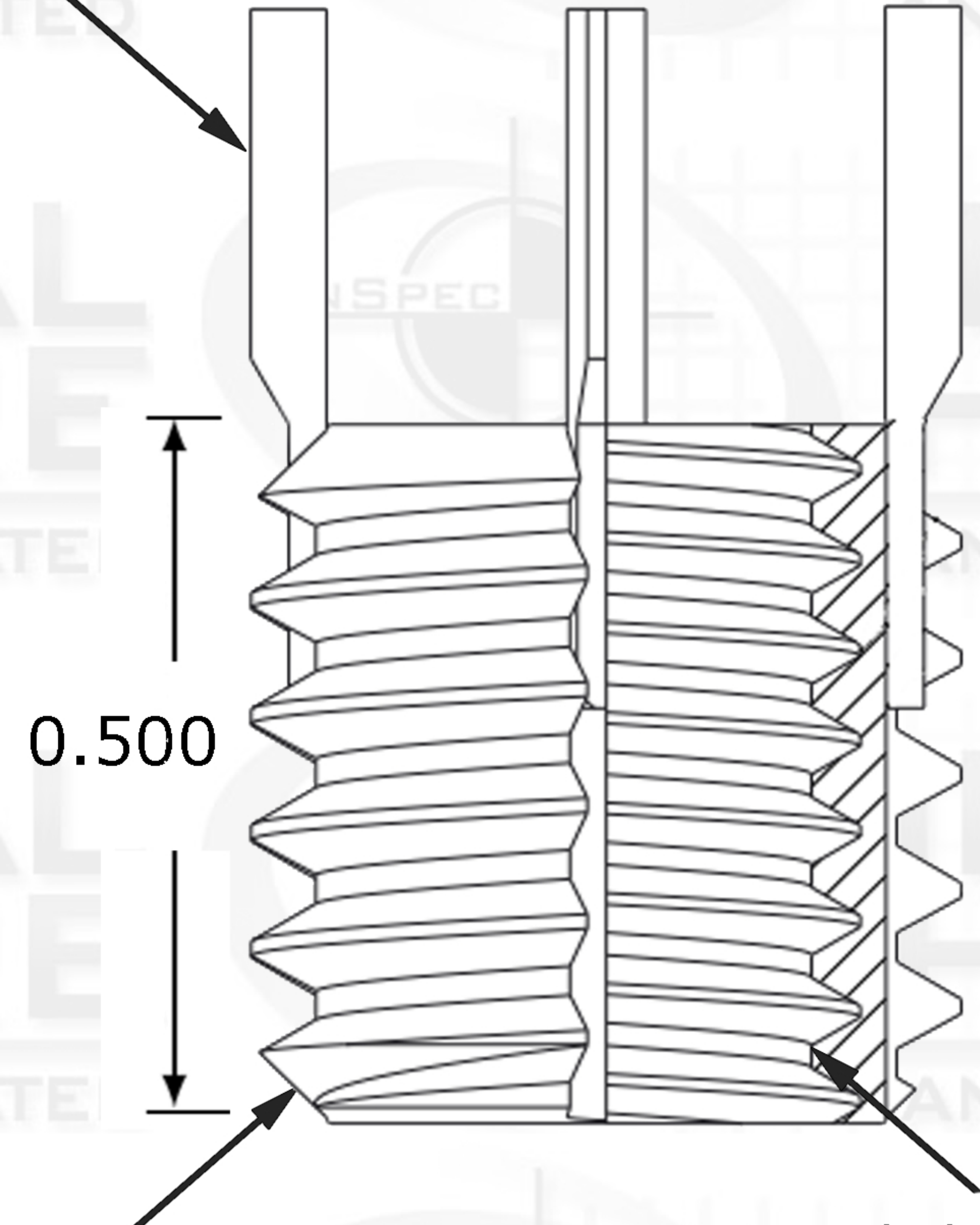

Key



0.500

External Thread Pitch  
5/8-11

Internal Thread Pitch  
3/8-16

Suggested Drill Bit Size



0.5782 (37/64)

## PROPRIETARY AND CONFIDENTIAL

THIS DRAWING AND IT'S CONTENT IS THE SOLE PROPERTY OF INDUSTRIAL HARDWARE & SPECIALTIES,INC.. ANY REPRODUCTION IN PART OR AS A WHOLE WITHOUT THE WRITTEN PERMISSION OF INDUSTRIAL HARDWARE & SPECIALTIES,INC. IS STRICTLY PROHIBITED.

		Internal	NAME	DATE
		TH. STANDARD: ANSI/ASME ACRONYM: UNC ROTATION: Right-Hand	DRAWN	
		<b>External</b> TH. STANDARD: ANSI/ASME ACRONYM: UNC ROTATION: Right-Hand	CHECKED	
		MATERIAL FINISH Carbon Steel C1215	ENG APPR.	
		PART NUMBER 35L8C-4RB4-37	MFG APPR.	
NEXT ASSY	USED ON		Q.A.	
			COMMENTS:	
APPLICATION		DO NOT SCALE DRAWING		



**17-B KENTUCKY AVENUE  
PATERSON, NEW JERSEY 07503  
TEL: 973-684-4010 FAX: 973-684-3095  
email: TechSupport@industrialhardware.com  
www.industrialhardware.com**

SIZE <b>A</b>	DWG. NO.	REV.
SCALE:1:8	WEIGHT:	SHEET 1 OF 1