

Key-Locking Internal Locking

| REVISIONS | | DATE | APPROVED |
|-----------|------|-------------|----------|
| ZONE | REV. | DESCRIPTION | |
| | | | |
| | | | |

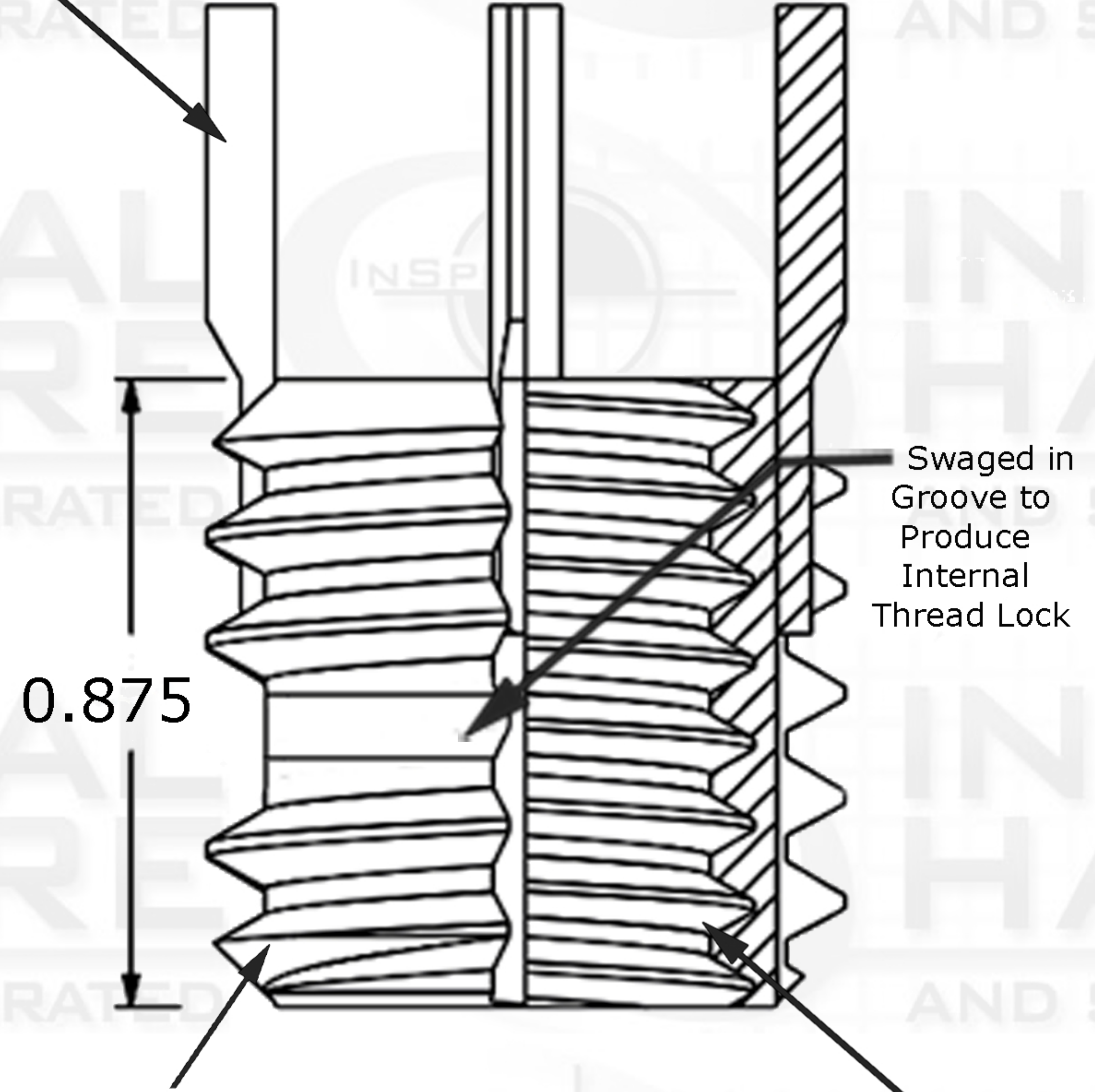

Key



0.875

Swaged in Groove to Produce Internal Thread Lock

External Thread Pitch

1-12

Internal Thread Pitch

5/8-11

Suggested Drill Bit Size



0.9375 (15/16)

PROPRIETARY AND CONFIDENTIAL

THIS DRAWING AND IT'S CONTENT IS THE SOLE PROPERTY OF INDUSTRIAL HARDWARE & SPECIALTIES,INC.. ANY REPRODUCTION IN PART OR AS A WHOLE WITHOUT THE WRITTEN PERMISSION OF INDUSTRIAL HARDWARE & SPECIALTIES,INC. IS STRICTLY PROHIBITED.

| | | | | | |
|-------------|---------|--------------------------|--|-----------|------|
| | | Internal | | NAME | DATE |
| | | TH. STANDARD : ANSI/ASME | | DRAWN | |
| | | ACRONYM: UNC | | CHECKED | |
| | | ROTATION: Right-Hand | | ENG APPR. | |
| | | External | | MFG APPR. | |
| | | TH. STANDARD : ANSI/ASME | | Q.A. | |
| | | ACRONYM: UNF | | | |
| | | ROTATION: Right-Hand | | | |
| | | MATERIAL FINISH | | | |
| | | Alloy Steel Type 4140 | | COMMENTS: | |
| NEXT ASSY | USED ON | PART NUMBER | | | |
| | | 35L8C-380A-062 | | | |
| APPLICATION | | DO NOT SCALE DRAWING | | | |



**17-B KENTUCKY AVENUE
PATERSON, NEW JERSEY 07503
TEL: 973-684-4010 FAX: 973-684-3095
email: TechSupport@industrialhardware.com
www.industrialhardware.com**

| | | |
|-----------|----------|--------------|
| SIZE | DWG. NO. | REV. |
| A | | |
| SCALE:1:8 | WEIGHT: | SHEET 1 OF 1 |