

# Key-Locking Non-Locking

ZONE		REV.	REVISIONS	DATE	APPROVED
			DESCRIPTION		

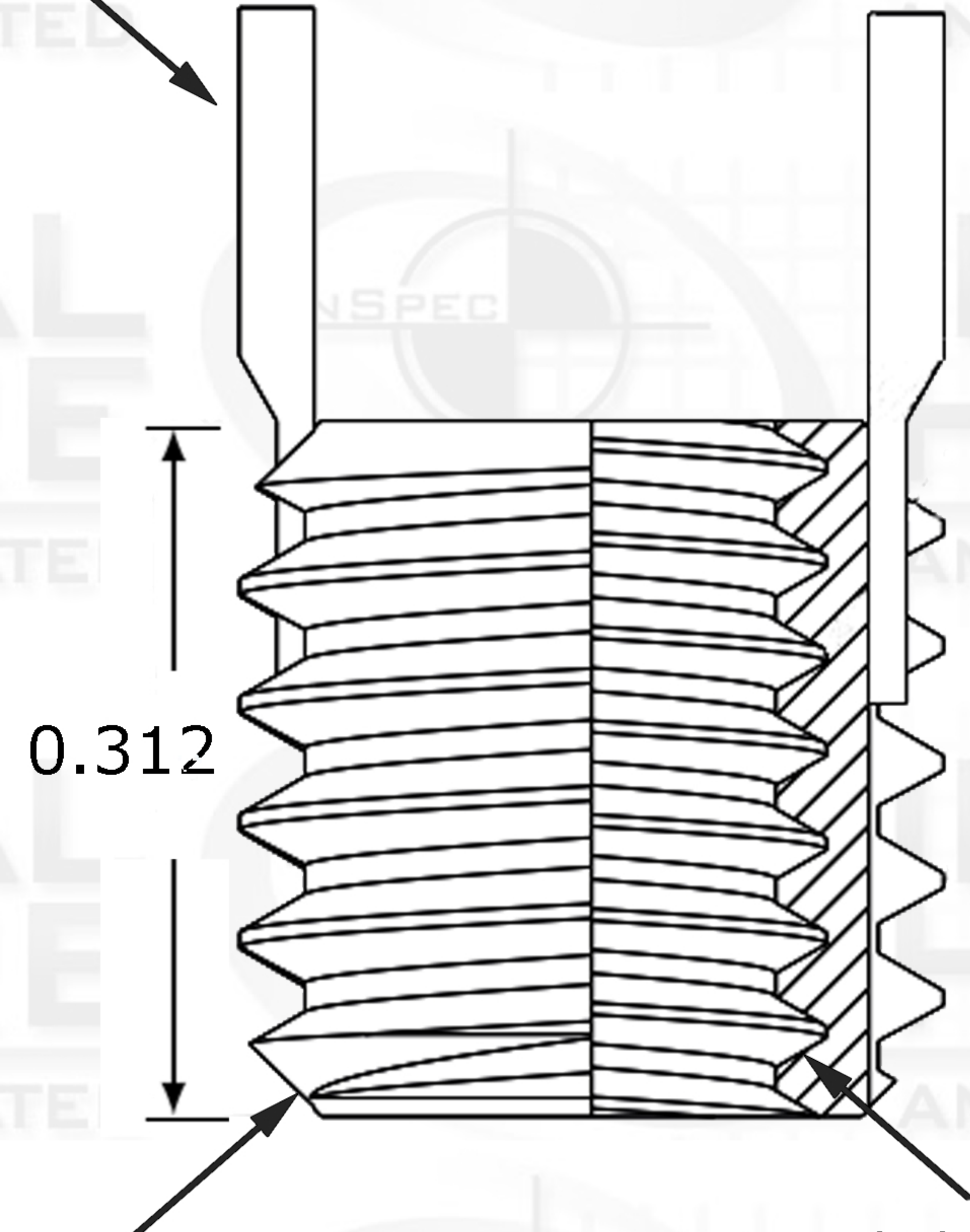

Key



0.312

External Thread Pitch  
7/16-14

Internal Thread Pitch  
10-24

Suggested Drill Bit Size



0.3970 (Letter X)

## PROPRIETARY AND CONFIDENTIAL

THIS DRAWING AND IT'S CONTENT IS THE SOLE PROPERTY OF INDUSTRIAL HARDWARE & SPECIALTIES,INC.. ANY REPRODUCTION IN PART OR AS A WHOLE WITHOUT THE WRITTEN PERMISSION OF INDUSTRIAL HARDWARE & SPECIALTIES,INC. IS STRICTLY PROHIBITED.

		<b>Internal</b>		NAME	DATE
		TH. STANDARD: ANSI/ASME		DRAWN	
		ACRONYM: UNC		CHECKED	
		ROTATION: Right-Hand		ENG APPR.	
		<b>External</b>		MFG APPR.	
		TH. STANDARD: ANSI/ASME		Q.A.	
		ACRONYM: UNC			
		ROTATION: Right-Hand			
		MATERIAL FINISH			
		Alloy Steel Type 4140			
NEXT ASSY	USED ON	PART NUMBER		COMMENTS:	
		35L8C-37GM-10-05			
APPLICATION		DO NOT SCALE DRAWING			



**17-B KENTUCKY AVENUE  
PATERSON, NEW JERSEY 07503  
TEL: 973-684-4010 FAX: 973-684-3095  
email: TechSupport@industrialhardware.com  
www.industrialhardware.com**

SIZE	DWG. NO.	REV.
<b>A</b>		
SCALE:1:8	WEIGHT:	SHEET 1 OF 1