

# Key-Locking Internal Locking

REVISIONS		DATE	APPROVED
ZONE	REV.	DESCRIPTION	

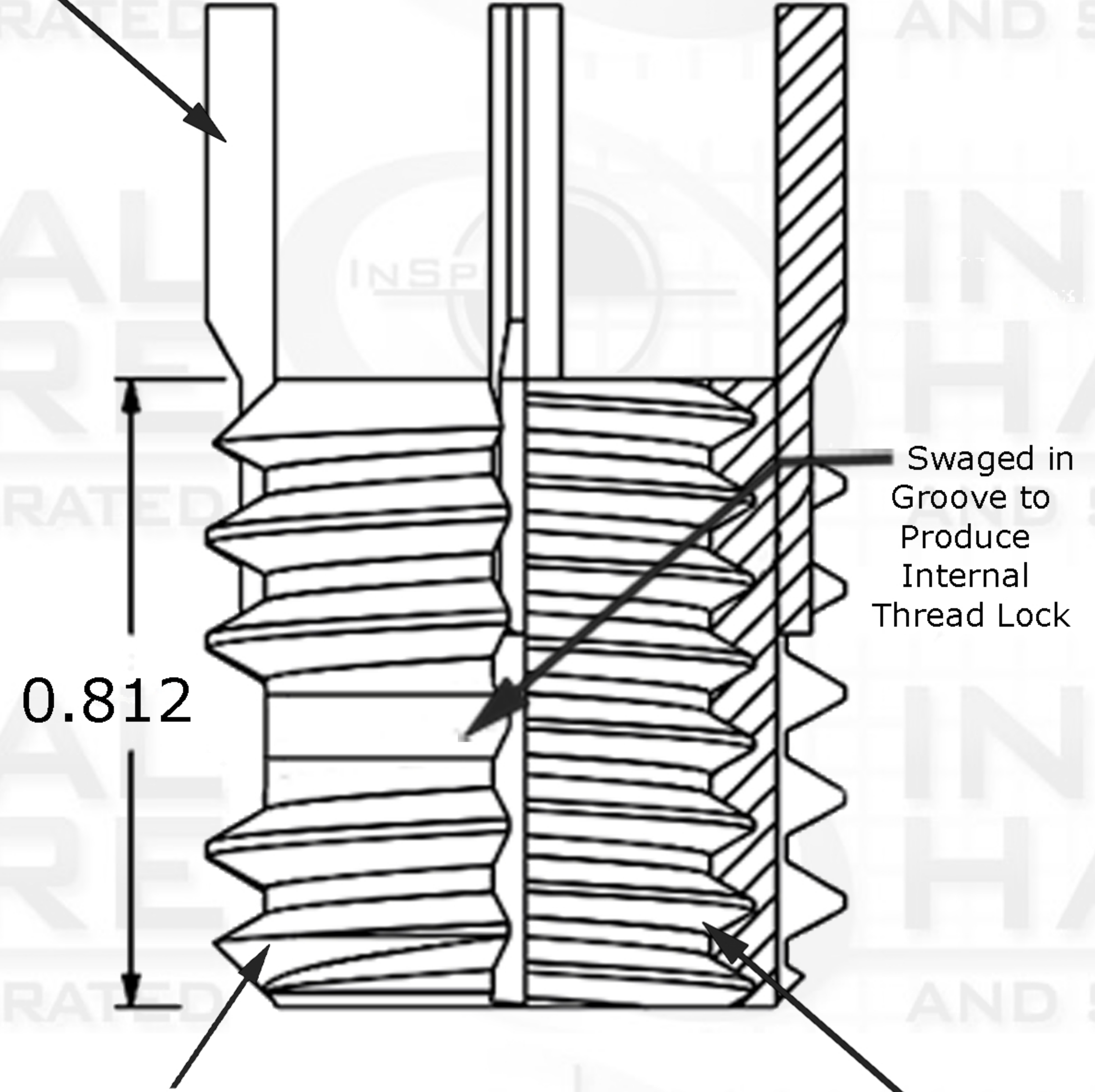

Key



0.812

Swaged in Groove to Produce Internal Thread Lock

External Thread Pitch

7/8-14

Internal Thread Pitch

9/16-12

Suggested Drill Bit Size



0.8282 (53/64)

## PROPRIETARY AND CONFIDENTIAL

THIS DRAWING AND IT'S CONTENT IS THE SOLE PROPERTY OF INDUSTRIAL HARDWARE & SPECIALTIES,INC.. ANY REPRODUCTION IN PART OR AS A WHOLE WITHOUT THE WRITTEN PERMISSION OF INDUSTRIAL HARDWARE & SPECIALTIES,INC. IS STRICTLY PROHIBITED.

		<b>Internal</b>		NAME	DATE
		TH. STANDARD : ANSI/ASME		DRAWN	
		ACRONYM: UNC		CHECKED	
		ROTATION: Right-Hand		ENG APPR.	
		<b>External</b>		MFG APPR.	
		TH. STANDARD : ANSI/ASME		Q.A.	
		ACRONYM: UNF			
		ROTATION: Right-Hand			
		MATERIAL FINISH			
		Alloy Steel Type 4140		COMMENTS:	
NEXT ASSY	USED ON	PART NUMBER			
		35L8C-3712-056			
APPLICATION		DO NOT SCALE DRAWING			



17-B KENTUCKY AVENUE  
 PATERSON, NEW JERSEY 07503  
 TEL: 973-684-4010 FAX: 973-684-3095  
 email: TechSupport@industrialhardware.com  
 www.industrialhardware.com

SIZE	DWG. NO.	REV.
<b>A</b>		
SCALE:1:8	WEIGHT:	SHEET 1 OF 1