



INSULATED EXTERIOR ACCESS DOOR

Model MX

For All Types of Construction



KARP ASSOCIATES, INC.
 260 Spagnoli Road Melville, NY 11747
 (631) 768-8300 - Phone
 (631) 768-8350 - Fax

DATE

SPECIFICATIONS

GENERAL SCOPE:

Access doors shall be Karp Type MX as manufactured by Karp Associates, Inc., Melville, N.Y. Sizes shall be as indicated on the drawings.

CONSTRUCTION:

1. Frame shall be 18 gauge galvanized steel.
2. Door shall be 18 gauge galvanized steel.
3. Door shall be sealed, watertight pan.
4. Trim shall one piece construction.
5. Gasketing between door and frame 3/8" wide by 1/8" thick closed cell neoprene gasketing.
6. Insulation shall be 1" thick polystyrene w/ 5.0 R-value.
7. Hinge shall be continuous galvanized piano hinge.
8. Latches shall be textured chrome lift & turn compression latch with gasket, keyed.
9. Finish shall be prime coat of rust inhibitive electrostatic powder, baked white enamel.

STANDARD SIZES (Special sizes on request)

DOOR SIZE H X W (IN.)	WALL/CEILING OPENING (IN.)	NUMBER OF STUD LATCHES	SHIP WT. (LBS.)
12 x 12	12 3/8 x 12 3/8	1	6.3
18 x 18	18 3/8 x 18 3/8	1	10.5
24 x 24	24 3/8 x 24 3/8	2	16.0
30 x 22	30 3/8 x 22 3/8	2	18.0
30 x 30	30 3/8 x 30 3/8	2	27.0
36 x 24	36 3/8 x 24 3/8	2	24.0
36 x 36	36 3/8 x 36 3/8	2	36.0

*Available in stainless steel

PROJECT DATA					
Project Name:					
Architect:					
Contractor:					
Agent/Customer Name:					
Tagging Instructions:					
Special Instructions:					

PROJECT SCHEDULE					
Qty.	H	W	No. of Latches	Finish	Remarks

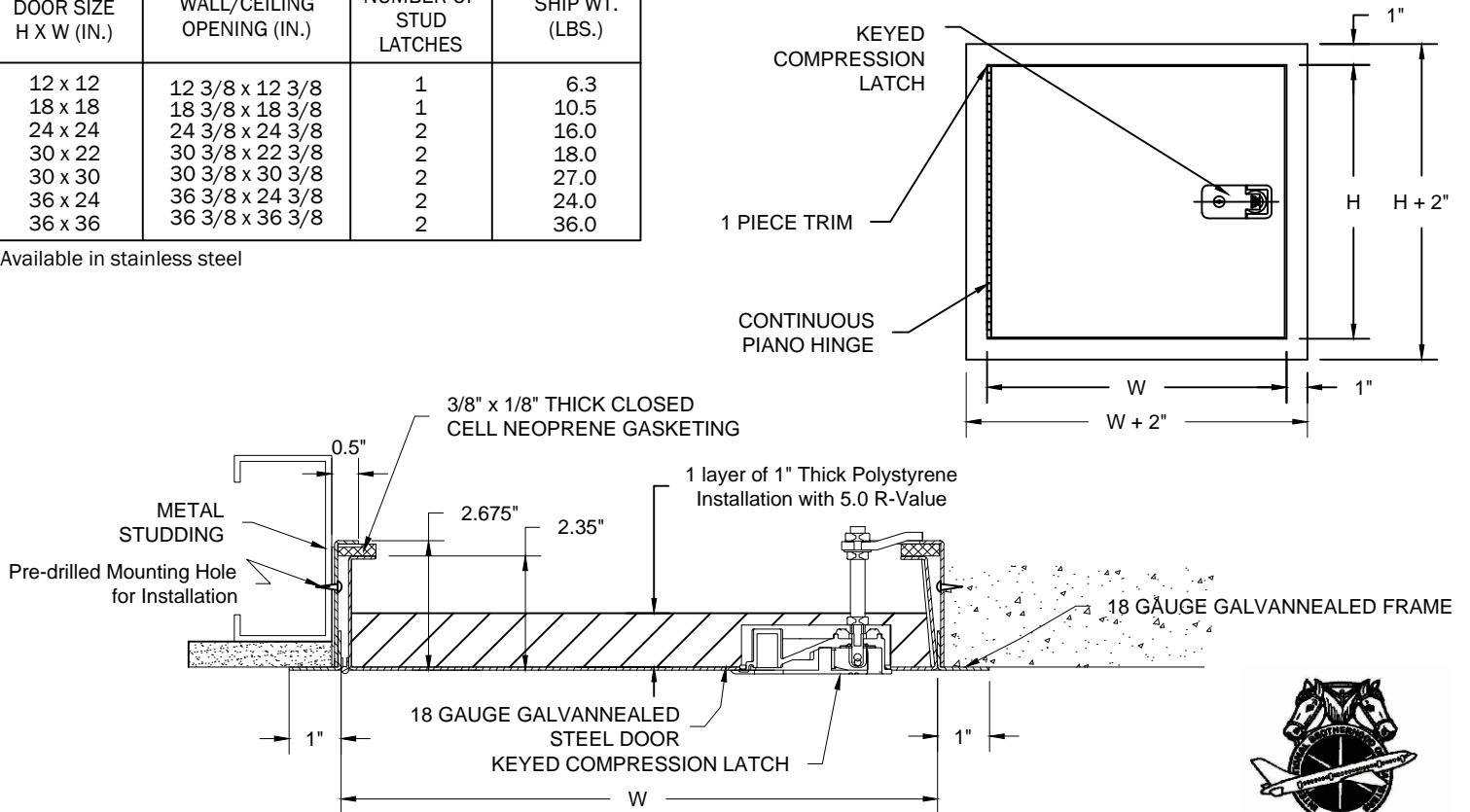

SECTION A-A



Made with Union Labor