



UNIVERSAL FLUSH ACCESS DOOR

Model DSC-214M

Prime Coated Steel or Stainless Steel

DATE



KARP ASSOCIATES, INC.
 260 Spagnoli Road Melville, NY 11747
 (631) 768-8300 - Phone
 (631) 768-8350 - Fax

SPECIFICATIONS

GENERAL SCOPE:

Access doors shall be Karp Type DSC-214M as manufactured by Karp Associates, Inc., Melville, N.Y. Sizes shall be as indicated on the drawings.

CONSTRUCTION:

1. Frame shall be 16 gage steel and door shall be 14 gage steel.
 2. Flange of frame shall be one-piece construction, 1.00" wide.
 3. Door and trim shall have radius corners.
 4. Hinge shall be pin type, spring loaded making door removable.
 5. Locks shall be flush and screwdriver operated with steel can and studs, or shall be key operated cylinder lock with automatic dust shutter.
 6. Masonry anchor straps can be included on frames if specified.
 7. Finish shall be prime coat of rust inhibitive electrostatic powder, baked white enamel. Stainless steel shall have No. 4 satin polish finish.
- * When hinge side is greater than 48", door shall have a continuous piano hinge for rigidity.

STANDARD SIZES

DOOR SIZE H X W (IN.)	WALL/CEILING OPENING (IN.)	# OF LATCHES		SHIP WT. (LBS.)
		CRS	SS	
6 x 6	6 3/8 x 6 3/8	1		2.1
8 x 8*	8 3/8 x 8 3/8	1		3.1
10 x 10*	10 3/8 x 10 3/8	1		4.3
12 x 8	12 3/8 x 8 3/8	1		4.6
12 x 12*	12 3/8 x 12 3/8	1		6.3
14 x 14	14 3/8 x 14 3/8	2		8.1
16 x 12	16 3/8 x 12 3/8	2		7.8
16 x 16	16 3/8 x 16 3/8	2		9.9
18 x 12	18 3/8 x 12 3/8	2		8.9
18 x 18*	18 3/8 x 18 3/8	2	4	12.2
20 x 16	20 3/8 x 16 3/8	2		11.8
22 x 22	22 3/8 x 22 3/8	4		16.3
24 x 12	24 3/8 x 12 3/8	2		10.6
24 x 18	24 3/8 x 18 3/8	2		14.5

* STOCK SIZES AVAILABLE IN S/S

PROJECT DATA					
Project Name:					
Architect:					
Contractor:					
Agent/Customer Name:					
Tagging Instructions:					
Special Instructions:					
To be purchased from Industrial Hardware & Specialties, Inc.					
www.industrialhardware.com					
T:973-684-4010 Fax:973-684-3095					



PROJECT SCHEDULE					
Qty.	H	W	No. of Latches	Finish	Remarks

DOOR SIZE H X W (IN.)	WALL/CEILING OPENING (IN.)	# OF LATCHES	SHIP WT. (LBS.)
24 x 20	24 3/8 x 20 3/8	2	16.5
24 x 24*	24 3/8 x 24 3/8	5	18.7
30 x 20	30 3/8 x 20 3/8	5	20.1
30 x 22	30 3/8 x 22 3/8	5	21.7
30 x 24	30 3/8 x 24 3/8	5	23.6
30 x 30	30 3/8 x 30 3/8	5	27.8
36 x 22	36 3/8 x 22 3/8	5	25.6
36 x 24	36 3/8 x 24 3/8	5	28.2
36 x 36	36 3/8 x 36 3/8	5	36.8
48 x 24	48 3/8 x 24 3/8	6	34.4

* The wall opening size for doors larger than 48 x 36 shall be 1/2" larger than the door size.

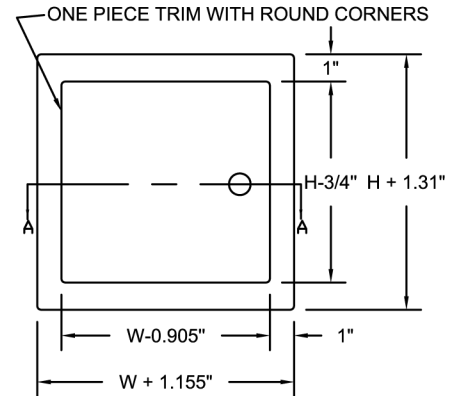
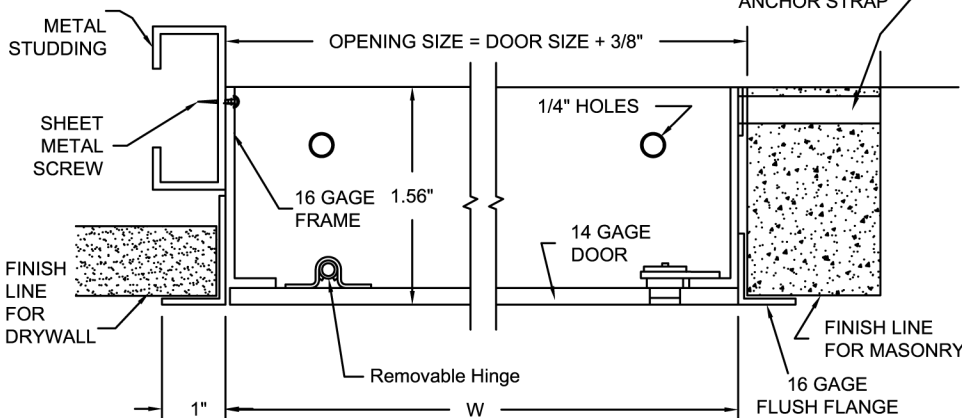

Made with Union Labor